



R-30 S

Pressure Sustaining Control Valve 2 Way

Introduction

Based on a unique technology that combines innovative design and performance, the Eliptix line of hydraulic control valves offers optimal system protection from transient pressures in the areas of waterworks, irrigation systems and landscape.

With an innovative elliptical structure, the Eliptix control valve line offers accurate, stable and excellent rates. The regulating capabilities for a wide range of flow rates from drip to maximum flow. Requiring exceptionally low operating pressure for valve opening and closing with rapid, yet gradual response to fluctuations in flow rates, the Eliptix valve is designed for minimal head loss and increased revenue.

With an exceptionally simple mechanism and a minimal amount of moving parts, the Eliptix hydraulic control valve line delivers reliable operation, extended durability and cavitation reduction resulting in significant cost reduction with minimal, fast and simple inline maintenance. Rugged, high quality construction meets applicable engineering standards.

Description

The Eliptix Pressure Sustaining Valve model R-30 S is activated by line pressure. The valve is normally closed. When the line pressure rises above a preset point, the Eliptix R-30 S Pressure Sustaining Valve opens to relieve the excess pressure downstream. When the line pressure drops, the Eliptix R-30 S valve closes. Eliptix R-30 S Pressure Sustaining Valve is used to maintain a minimum upstream pressure.

Product Features

- Rugged, high quality construction meets applicable engineering standards
- Long service life and low maintenance
- Unique technology, innovative design and performance
- Free and unobstructed liquid flow with minimal head loss
- Designed to reduce cavitation
- Elliptic diaphragm reacts faster with less movement
- Small control chamber enables quicker response

Schematic Control Loop Diagram

COMPONENTS

1. Y - Strainer
2. Ball Valve
3. Pressure Gauge
4. P-26 S pressure sustaining pilot valve

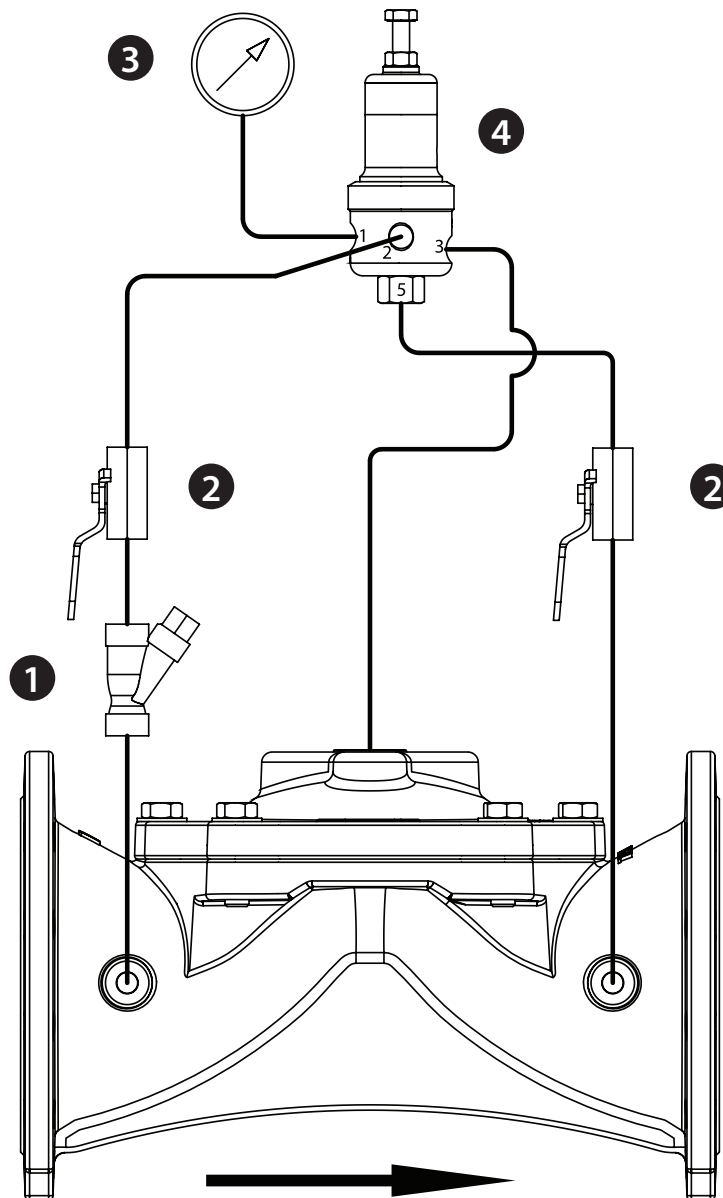

Pressure Sustaining Control Valve - 2 Way

Purchase Specifications

The Hydraulic Control Valve shall automatically control upstream pressure to maintain the minimum preset pressure, regardless of changes in the downstream pressure or in the flow rate.

The control valve shall be a hydraulically operated, pilot controlled, weir type, in-line serviceable valve.

The main in-line hydraulic control valve shall have only two moving parts, the resilient diaphragm and the spring.

The diaphragm shall be the only sealing component of the control valve.

Valve Technical Specifications*

Series R-30 PN16

Self-actuated, WEIR type diaphragm actuated, hydraulic control valve

*For dimensions and weights, please refer to the Eliptix Basic Valve leaflet

Material	Body & Bonnet	Ductile Iron / Stainless Steel SAE 316
	Diaphragm	Natural Rubber / EPDM
	Spring	Stainless Steel SAE 302
	Spring Seat	Acetal / Stainless Steel SAE 316
	Bolts	Steel, Zinc Cobalt Coated / Stainless Steel SAE 316
	Piping & Tubing	Stainless Steel SAE 316 / Reinforced Nylon
	Coating	Polyester
Pressure Rating	Maximum working pressure - 16 bar Minimum working pressure - 0.4 bar (depending on type of diaphragm)	
Water Temp. Range	5° to 60°C	

Pilot Valve Technical Specifications

Model: **P-26 S** PN16

Spring loaded 2W hydraulic control pilot valve

Material	Body	Brass – Nickel Plated / Stainless Steel 316
	Internal Parts	Elastomers: EPDM / NBR Metal: Stainless Steel SAE 316 / Brass
	Spring	Stainless Steel SAE 302
Pressure Rating	Maximum working pressure - 16 bar Minimum working pressure - 0.4 bar	
Water Temp. Range	5° to 60°C	

Installation and Storage Recommendations

- Always flush the pipeline to remove debris before the installation of the valve.
- Arrow on the valve bonnet must match the actual flow direction.
- Tighten bolts to the recommended torque for the specific size and model of the Eliptix valve.
- Do not over-torque.
- Tighten bolts using the crossover method.
- If the Eliptix valve is for use in ambient or fluid temperatures below freezing, consult your nearest A.R.I. distributor. If shut down during cold weather, the valve control space and the control system must be drained.

When ordering, please specify

- 1) Eliptix Control Valve Series R-30 model S
- 2) Eliptix valve size
- 3) Desired End Connection / Standard
- 4) Static inlet pressure (when valve is closed)
- 5) Dynamic pressures (min – max)
- 6) Flow rates (min-max)
- 7) Required sustaining pressure