

S-050 PN 16

S-050-C PN 16 / S-052 PN 25



Automatic Air Release Valve

Description

The S-050 series Automatic Air Release Valve releases accumulated air from the system while it is under pressure. The presence of air in a water system can reduce the effective cross sectional flow area resulting in increased head loss and decreased flow. Unwanted air may also cause water hammer and metering inaccuracies, while hastening corrosion. In spite of its compact and light weight structure, the S-050 series Automatic Air Release Valve has a 12mm² orifice that enables it to release air at high flow rates and is not exposed to obstruction by debris.

Applications

- On most types of pumps.
- After filters, pressure reducers and fertilizer injection systems.
- On heads of landscape systems.

S-050-C, S-052 additional applications:

- Water pipelines vulnerable to vandalism and/or water theft.
- Water systems found in remote areas.

Operation

The automatic air release valve releases entrapped air from pressurized systems.

Without air release valves, pockets of accumulated air may cause the following hydraulic disturbances:

- Restriction of effective flow due to a reduction of the flow area. In extreme cases this will cause complete flow stoppage.
- Obstruction of efficient hydraulic transmission due to air flow disturbances.
- Acceleration of cavitation damages.
- Increase in pressure transients and surges.
- Internal corrosion of pipes, fittings and accessories.
- Dangerous high-energy bursts of compressed air.
- Inaccuracies in flow metering.

As the system fills and is pressurized, the automatic air release valve functions according to the following stages:

1. Entrapped air, which accumulates at peaks and along the system, rises to the top of the air valve, which in turn displaces the liquid in the air valve body.
2. The float drops, unsealing the rolling seal. The automatic air release orifice opens and the accumulated air is released.
3. Liquid enters the valve and the float rises, pushing the rolling seal back to its sealing position.

Note: Automatic air release valves are designed to release air as it accumulates at peaks in pressurized systems. They are not normally recommended for vacuum protection or for discharging large volumes of air, because of their inherently small orifices. For this

purpose, air & vacuum valves are recommended as they have much larger orifices.

However, air release valves will permit air to enter the system under vacuum conditions. If this is not desirable, specify the one-way out check valve.

Main Features

- Working pressure range:
 - S-050 0.2 - 16 bar
 - S-050-C 0.2 - 16 bar
 - S-052 0.2 - 25 bar
- Test pressure for the air valve is 1.5 times its working pressure.
- Maximum working temperature: 60°C.
- Maximum intermittent temperature: 90°C.
- The body is made of high strength composite materials and all operating parts are made of specially selected corrosion-resistant materials.
- The larger than usual orifice enables it to release air at higher flow rates than other automatic air release valves of its kind.
- The enlarged orifice and self cleaning rolling seal make it less exposed to obstruction by debris.
- The valve's rolling seal mechanism design is less sensitive to different pressures than a direct float seal, thus enabling a one size orifice for a wide pressure range (from 0.2 up to 25 bar).
- Lightweight, simple and reliable structure.
- A discharge outlet enables removal of excess fluids.

Valve Selection

- Available in male threaded sizes: 1/2", 3/4", 1" - BSP / NPT
- S-050 is rated for 16 bar.
- S-050-C vandalism protected by a metal shell covering the air release component, rated for 16 bar.
- S-052 vandalism protected by a metal shell covering the air release component, rated for 25 bar.
- SG-10 For low pressures (0.2-10 bar)
- S-050 LP For low pressures (0.05-6 bar)
- S-050 B With a brass base (0.2-16 bar)
- S-050 V, S-050-C-V Vacuum check valve - Available as a valve that will only release air from the system and will not admit air to the system when negative pressure conditions occur. This characteristic is obtained by adding a check valve to the air outlet.

Note

For best suitability, it is recommended to send the fluid chemical properties along with the valve request.

Upon ordering, please specify: model, size, working pressure, thread and flange standard and type of liquid.



S-050 S-050 B S-050-C S-052

S-050 / S-050 B

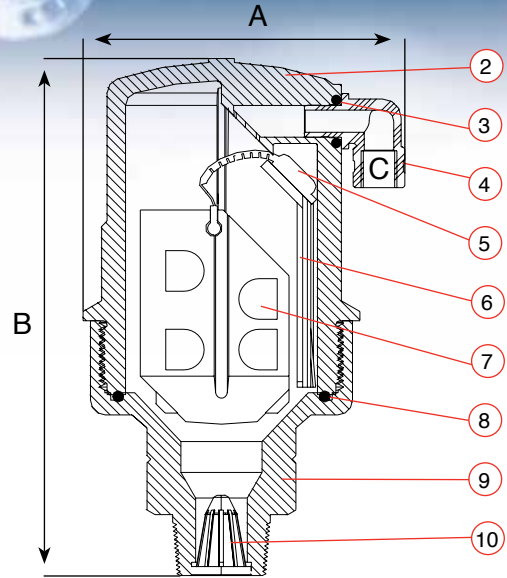

DIMENSIONS AND WEIGHTS

Model	Dimensions mm		Connection C	Weight Kg.	Orifice Area mm ²
	A	B			
S-050	87	143	1/8" BSP Female	0.3	12
S-050 B	87	143	1/8" BSP Female	0.65	12
S-050-C	85	148	1/8" BSP Female	1.65	12
S-052	85	148	1/8" BSP Female	1.65	9

PARTS LIST AND SPECIFICATION

No.	Part	Material
1.	Shell	Ductile Iron
2.	Body	Reinforced Nylon
3.	Air Release Outlet	
	S-050	Polypropylene
	S-050-C/S-052	Brass
4.	O-Ring	BUNA-N
5.	Rolling Seal	EPDM
6.	Clamping Stem	Reinforced Nylon
7.	Float	Foamed Polypropylene
8.	O-Ring	BUNA-N
9.	Base	
	S-050	Reinforced Nylon / Brass
	S-050-C/S-052	Brass
10.	Strainer	Nylon

S-050-C / S-052

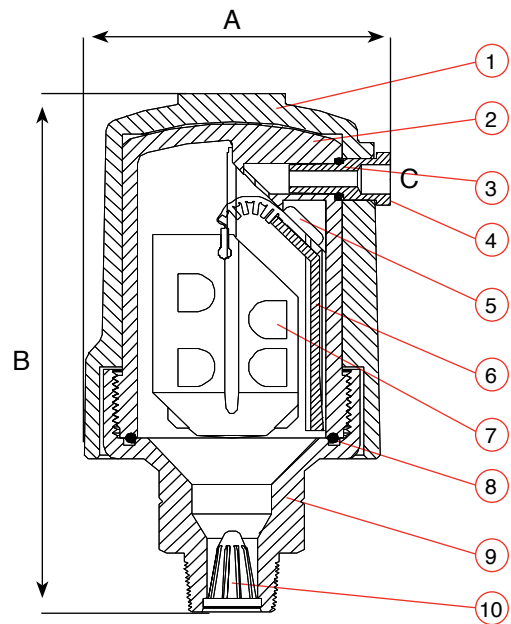

S-050 / S-050-C AUTOMATIC AIR RELEASE FLOW RATE

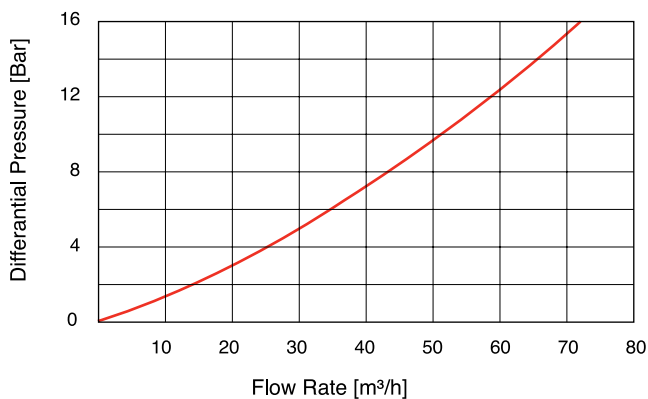

S-052 AUTOMATIC AIR RELEASE FLOW RATE

