

INSTALLATION GUIDE

This section deals with installation recommendations for wastewater systems. Included are recommendations for sizing the pipeline risers and the placement of air valves on the various sections of the system. Further information can be obtained by contacting the local agent or the A.R.I. applications engineering dept.

Recommendation for Riser Dimensions

$d=D$ for $D \leq 300$ mm
 $d=0.6 D$ for $300 \text{ mm} < D \leq 1500$ mm
 $d \geq 0.35 D$ for $D > 1500$ mm

$h \geq D$ or $h=D/2$ and $h \geq 150$ mm

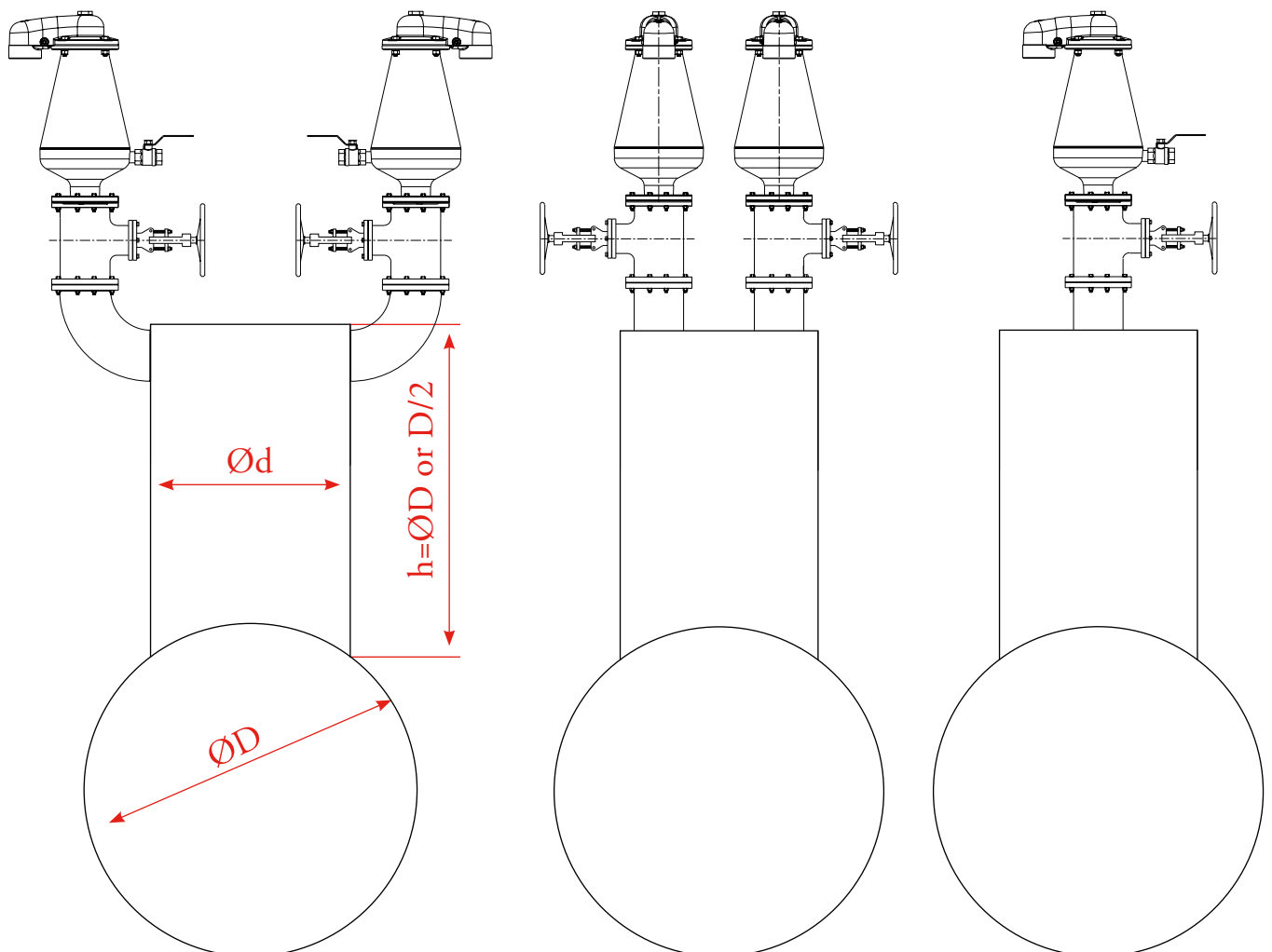

Sample Setups for Pump Stations

Air Valve Location:

An air valve shall be installed between the pump and the check valve.

The diameter and pressure of the air valve will be determined according to the design of the system.

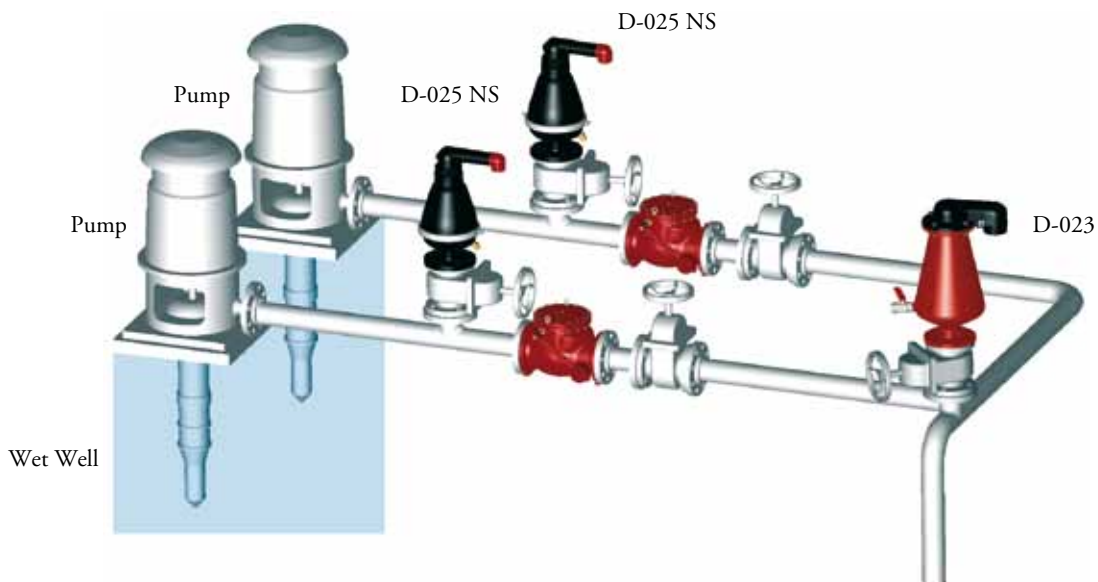

Air Valve Type According to Pump Type:

A non slam type combination air valve shall be installed after a submersible or suction type pump.
An automatic air valve shall be installed after the dry well pump.

Pumping with a submersible pump.

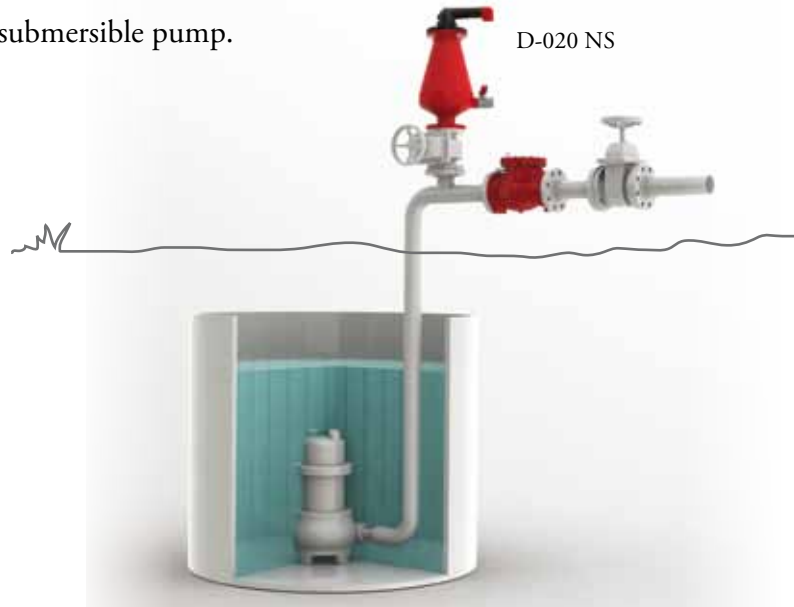

Suction pumping
(Centrifugal / Progressive Cavity pump).

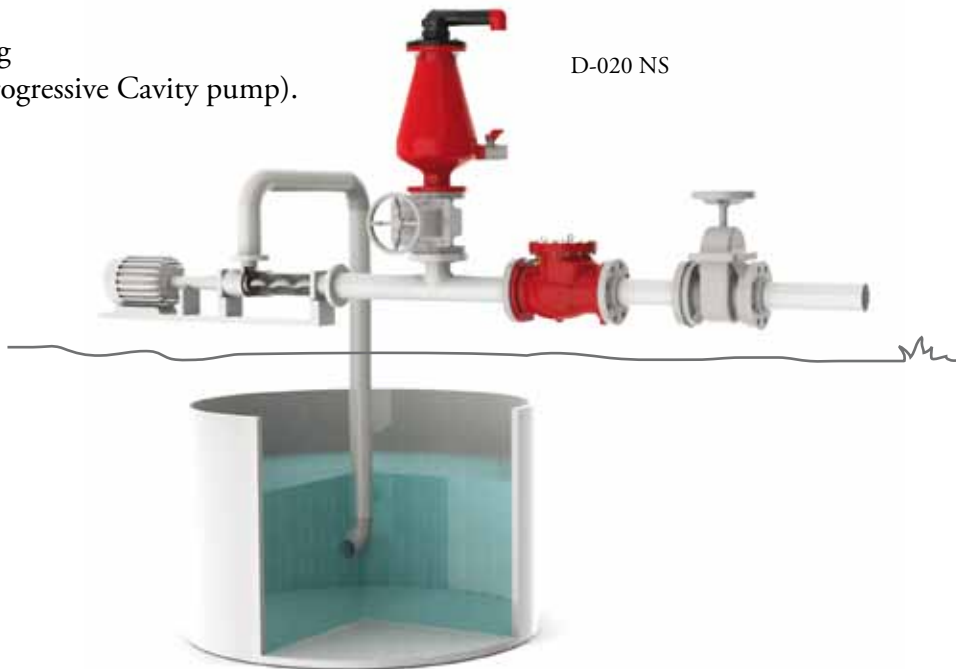

Dry well pumping.



Sample Air Valves Applications at Isolating Valves

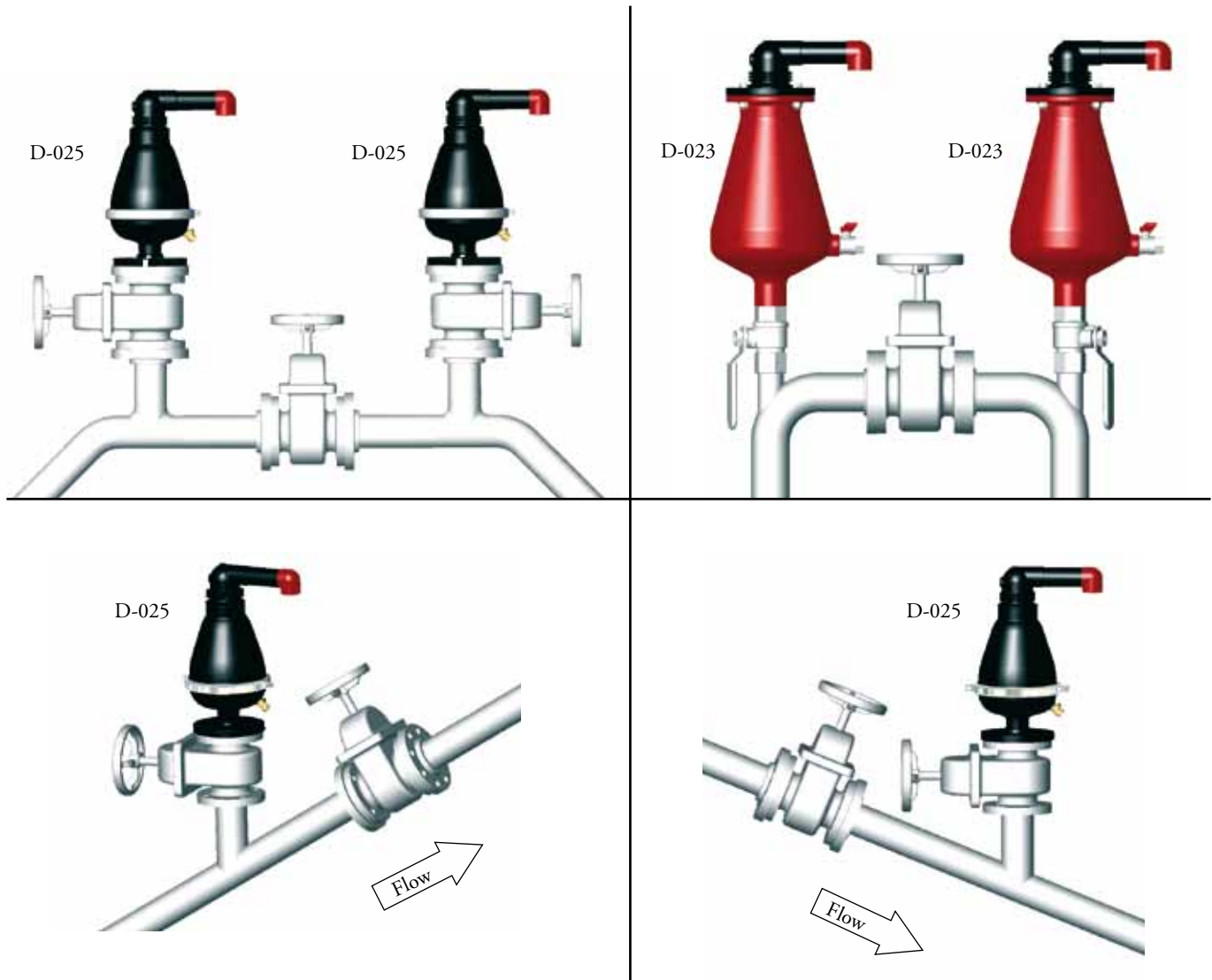

Sample Installation Scheme for Underground Air Valves

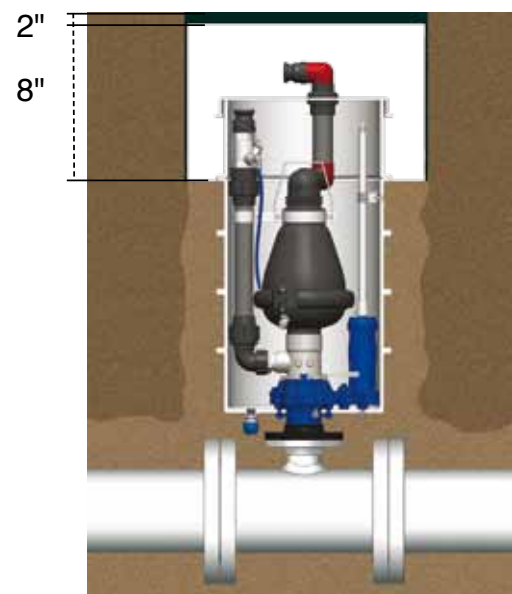

Air Valve Location at Pump Stations and on Transmission Lines

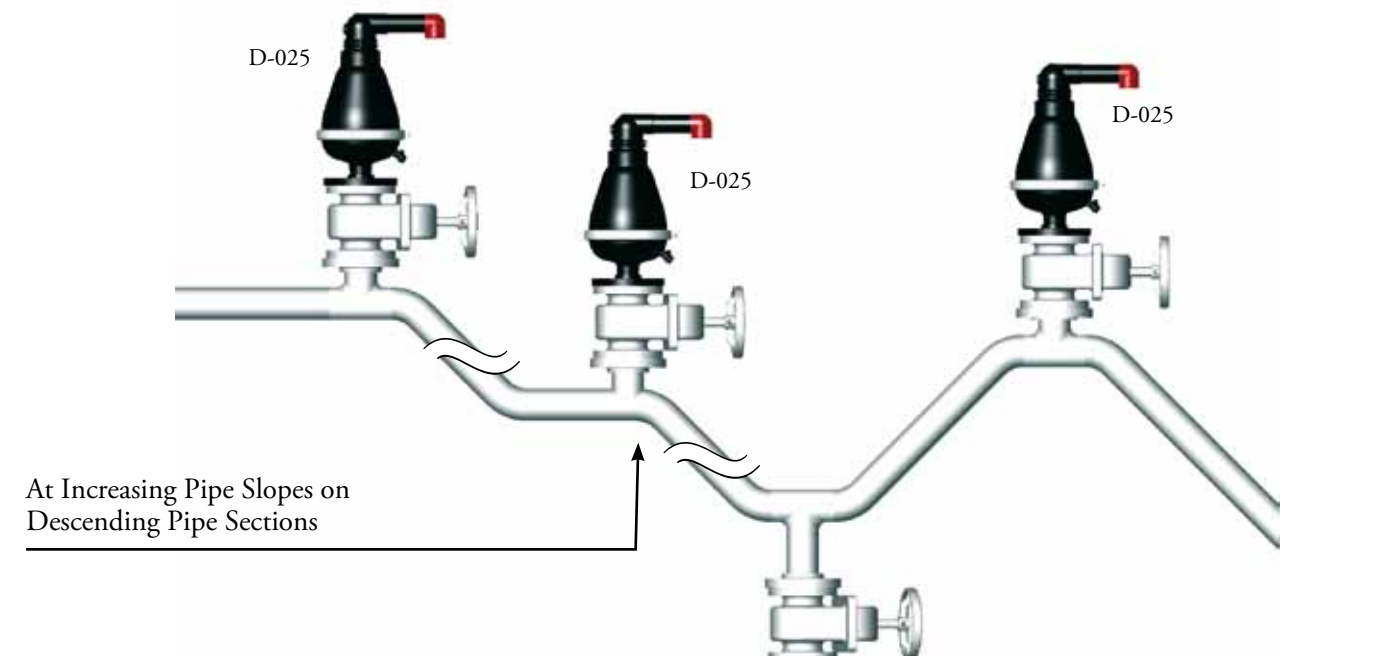
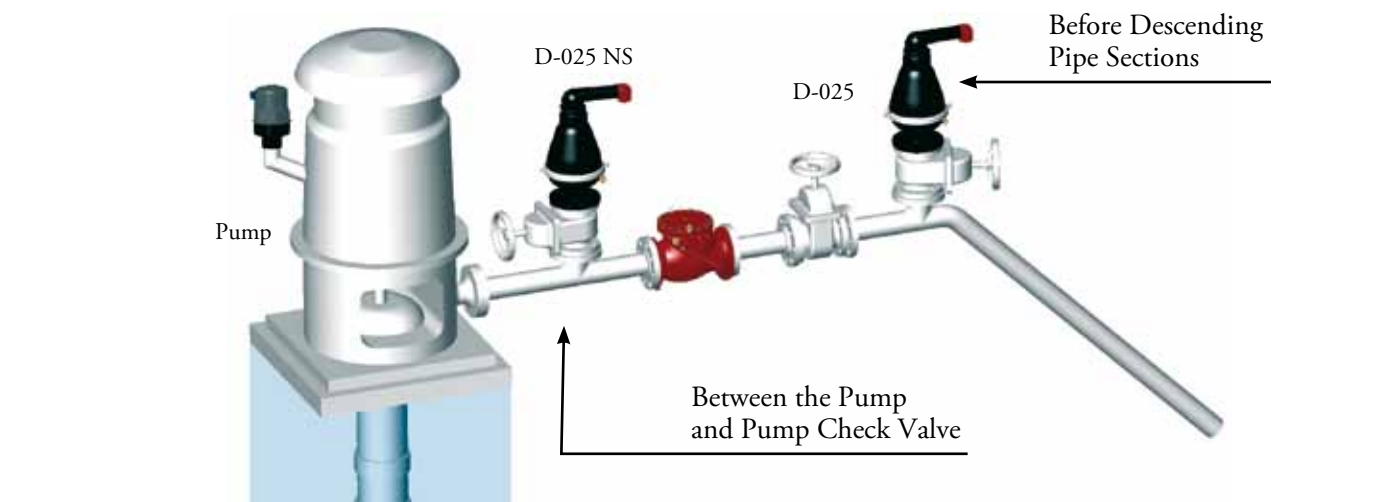
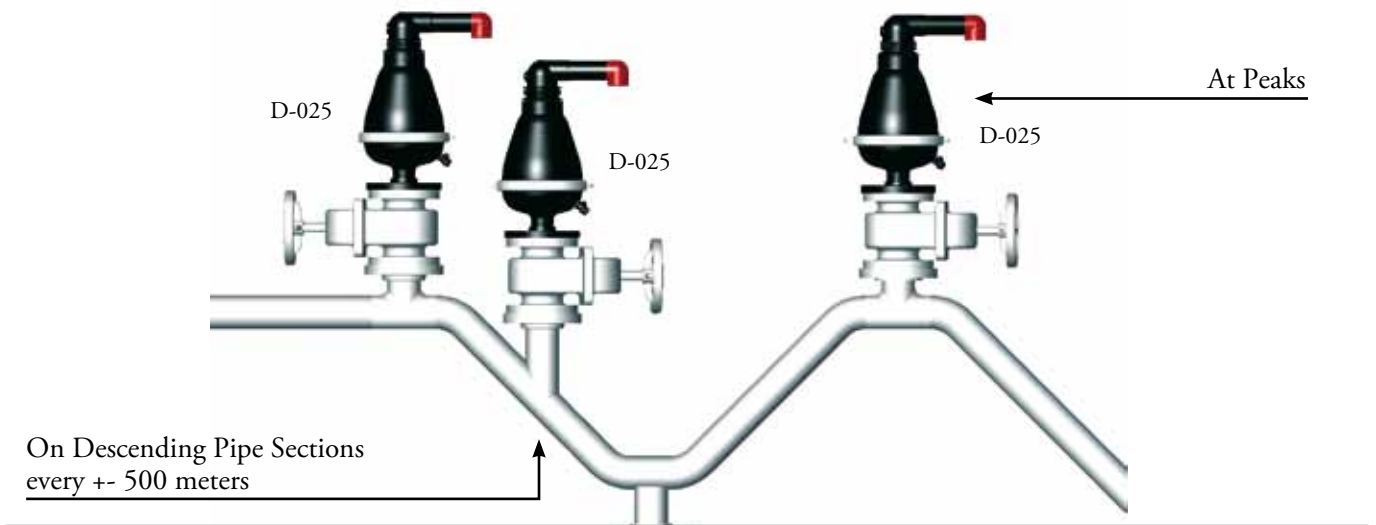

At the Ends of Overhead Crossings → D-025

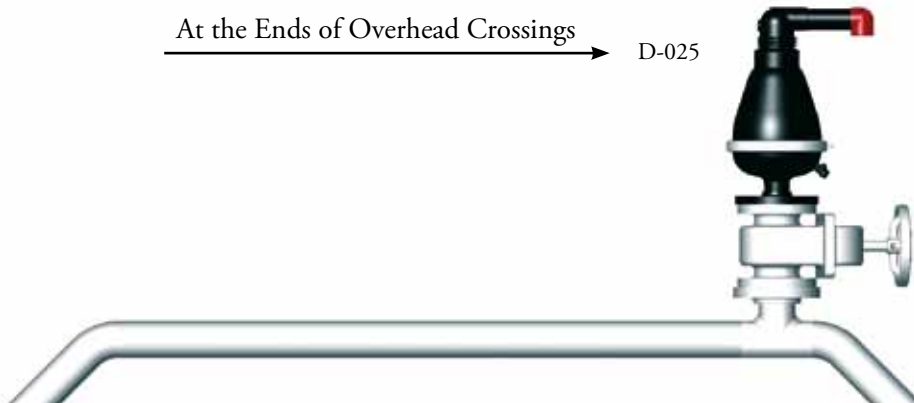

At the Ends of Underground Road Crossings



Air Discharge at Dead Ends → D-025

