



D-050_{PN 16}

D-050-C_{PN16}

D-052_{PN25}



Combination Air Valve

Description

The D-050 Combination Air Valve has the features of both an air release valve and an air & vacuum valve.

The air release component is designed to automatically release small pockets of air to the atmosphere as they accumulate along a pipeline or piping system when it is full and operating under pressure.

The air & vacuum component is designed to automatically discharge or admit large volumes of air during the filling or draining of a pipeline or piping system. This valve will open to relieve negative pressures whenever water column separation occurs.

Applications

- Municipal and industrial water conveyance systems.

D-050-C D-052 - additional applications

- Water pipelines vulnerable to vandalism and/or water theft.
- Water systems found in remote areas.

Operation

The air & vacuum component, with the large orifice, discharges air at high flow rates during the filling of the system and admits air into the system at high flow rates during its drainage and at water column separation.

High velocity air will not blow the float shut. Water will lift the float which seals the valve.

At any time during system operation, should internal pressure of the system fall below atmospheric pressure, air will enter the system.

The smooth discharge of air reduces pressure surges and other destructive phenomena.

The intake of air in response to negative pressure protects the system from destructive vacuum conditions and prevents damage caused by water column separation. Air entry is essential to efficiently drain the system.

The air release component releases entrapped air in pressurized systems.

Without air valves, pockets of accumulated air may cause the following hydraulic disturbances:

- Restriction of effective flow due to a reduction of the flow area. In extreme cases this will cause complete flow stoppage.
- Obstruction of efficient hydraulic transmission due to air flow disturbances.
- Acceleration of cavitation damages.

- Increase in pressure transients and surges.
- Internal corrosion of pipes, fittings and accessories.
- Dangerous high-energy bursts of compressed air.
- Inaccuracies in flow metering.

As the system fills and is pressurized, the combination air valve functions in the following stages:

1. Air in the pipeline is discharged by the air valve.
2. Liquid enters the air and vacuum component, lifting the float to its sealing position.
3. Liquid enters the air release component of the valve, lifting the float and pushing the rolling seal to its sealing position.
4. Entrapped air, accumulating at peaks and along the system, rises to the top of the air release valve, displacing the liquid in the valve's body.
5. The float drops, unsealing the rolling seal. The air release orifice opens and the accumulated air is released.
6. Liquid replaces the air released from the valve, buoying up the float and pushing the rolling seal back to its sealing position.

When internal pressure falls below atmospheric pressure (negative pressure):

1. The floats will drop down, immediately opening the air & vacuum and air release orifices.
2. Air will enter into the system.

Main Features

- Working pressure range:
 - D-050, D-050-C – 0.2 - 16 bar
 - D-052 – 0.2 - 25 bar
- Testing Pressure: 1.5 times the working pressure of the air valve.
- Maximum working temperature: 60° C.
- Maximum intermittent temperature: 90° C.
- Reliable operation reduces water hammer incidents.
- Dynamic design allows for high capacity air discharge while preventing premature closure.
- Lightweight, small dimensions, simple and reliable structure.
- Special orifice seat design: combination of bronze and E.P.D.M. rubber assures long-term maintenance-free operation.
- The discharge outlet enables the connection of a vent pipe.

Air Release Component

- Body made of high strength materials.

- All operating parts are made of specially selected corrosion-resistant polymer materials.
- Large sized air release orifice:
 - Dramatically reduces the possibility of obstruction by debris.
 - Discharges high air flow rates.
 - One size orifice for a wide pressure range (up to 25 bar), achieved by the rolling seal mechanism.

Valve Selection

- Connection size range: 2- 8".
- D-050 rated for 16 bars.
- D-050-C vandalism protected by a metal shell covering the air release component, rated for 16 bar.
- D-052 vandalism protected by a metal shell covering the air release component, rated for 25 bar.
- These valves are manufactured with flanged ends to meet any requested standard.
- The 2" valve is also available with a threaded BSP or NPT connection.
- Valve coating: fusion bonded epoxy coating according to the standard DIN 30677-2.
- Other coatings are available upon request.
- The automatic air release component and the air & vacuum component are available as separate units.

Note

For best suitability, it is recommended to send the fluid chemical properties along with the valve request. Upon ordering, please specify: model, size, working pressure, threads standard and type of liquid.

AIR & VACUUM FLOW RATE

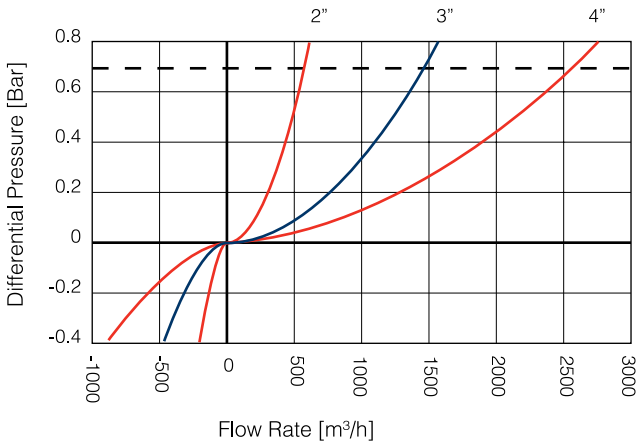

— — — Max. recommended design air discharge

AIR & VACUUM FLOW RATE

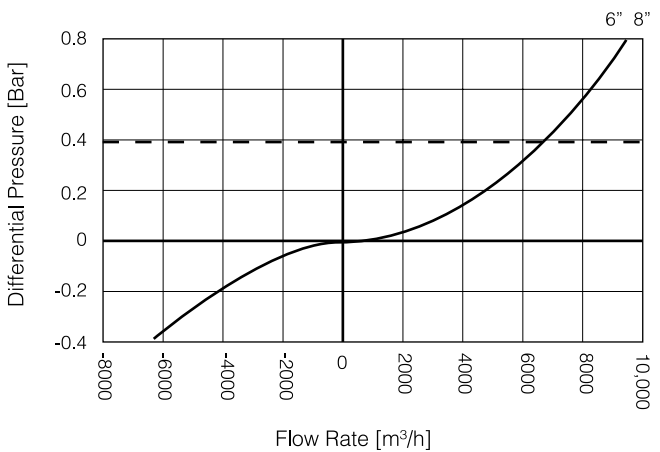

D-050 / D-050-C AUTOMATIC AIR RELEASE FLOW RATE

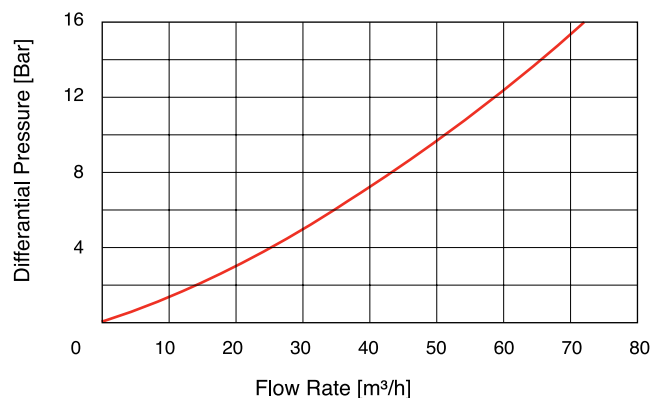

D-052 AUTOMATIC AIR RELEASE FLOW RATE

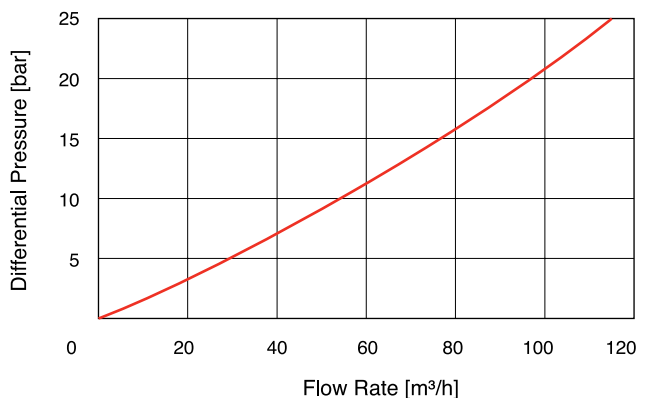

D-050

DIMENSIONS AND WEIGHTS

Nominal Size	Dimensions mm		Connections		Weight Kg.	Orifice Area mm ²	
	A	B	C	D		A / V	Auto.
2" (50mm) Threaded	173	293	1½" BSP Female	1/8" BSP Female	4.3	794	12
2" (50mm) Flanged	173	306	1½" BSP Female	1/8" BSP Female	6.4	794	12
3" (80mm) Threaded	184.3	329	2" BSP Female	1/8" BSP Female	10	1809	12
3" (80mm) Flanged	211	328	2" BSP Female	1/8" BSP Female	13	1809	12

Nominal Size	Dimensions mm				Connection D	Weight Kg.	Orifice Area mm ²	
	A	B	internal C	external			A / V	Auto.
4" (100mm)	342	382	80.0	96.0	1/8" BSP Female	26.4	3317	12
6" (150mm)	399	432	90	106	1/8" BSP Female	43.5	7850	12
8" (200 mm)	553	554	124.0	140.0	1/8" BSP Female	117	17662	12

D-050-C / D-052

DIMENSIONS AND WEIGHTS

Nominal Size	Dimensions mm		Connections		Weight Kg.	Orifice Area mm ²		
	A	B	C	D		A / V	Auto. D-050-C / D-052	
2" (50mm) Threaded	168	302	1½" BSP Female	1/8" BSP Female	5.7	794	12	9
2" (50mm) Flanged	168	315	1½" BSP Female	1/8" BSP Female	7.8	794	12	9
3" (80mm) Threaded	182	336.5	2" BSP Female	1/8" BSP Female	11.5	1809	12	9
3" (80mm) Flanged	205	339	2" BSP Female	1/8" BSP Female	14.4	1809	12	9

Nominal Size	Dimensions mm				Connection D	Weight Kg.	Orifice Area mm ²		
	A	B	internal C	external			A / V	Auto. D-050-C / D-052	
4" (100mm)	342	393	80.0	96.0	1/8" BSP Female	27.4	3317	12	9
6" (150mm)	399	439	90	106	1/8" BSP Female	44.9	7850	12	9
8" (200 mm)	553	560	124.0	140.0	1/8" BSP Female	118.0	17662	12	9

PARTS LIST AND SPECIFICATION 2", 3"

No.	Part	Material
1.	Body	Reinforced Nylon
2.	Air Release Outlet	Polypropylene
3.	Rolling Seal	EPDM
4.	Clamping Stem	Reinforced Nylon
5.	Float	Foamed Polypropylene
6.	O-Ring	BUNA-N
7.	Base	Reinforced Nylon
8.	Strainer	Nylon
9.	Cover	Ductile Iron
10.	Orifice Seat	Bronze
11.	Orifice Seal	EPDM
12.	O-Ring	BUNA-N
13.	Bolt, Nut & Washer	Steel, Zinc Cobalt coated
14.	Body	Ductile Iron
15.	Float	Polycarbonate / Stainless Steel 316

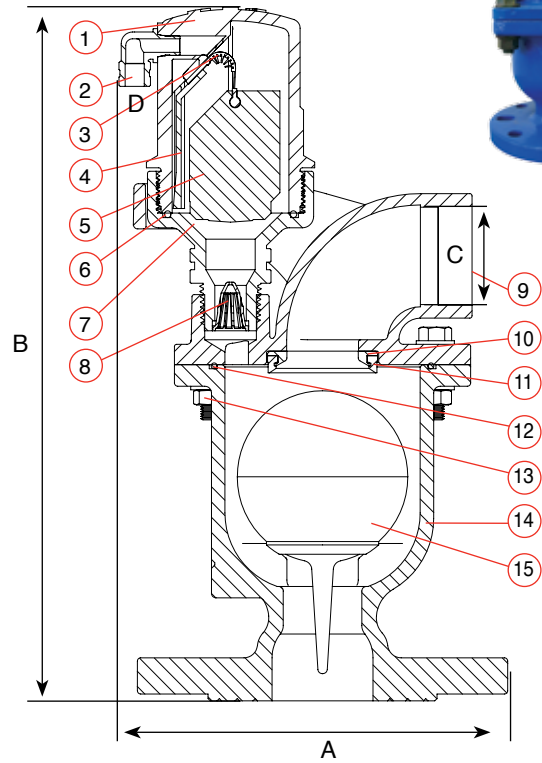

PARTS LIST AND SPECIFICATION 4", 6", 8"

No.	Part	Material
1.	Body	Reinforced Nylon
2.	Air Release Outlet	Polypropylene
3.	Rolling Seal	EPDM
4.	Float	Foamed Polypropylene
5.	Clamping Stem	Reinforced Nylon
6.	O-Ring	BUNA-N
7.	Base	Brass
8.	Strainer	Nylon
9.	Orifice Seat	Bronze
10.	Orifice Seal	EPDM
11.	Cover	Ductile Iron
12.	O-Ring	BUNA-N
13.	Bolt, Nut & Washer	Steel Zinc Cobalt Plated
14.	Float	Polycarbonate / Stainless Steel
15.	Body	Ductile Iron
* Screen Cover 10"-12"		Polyethylene / Ductile Iron

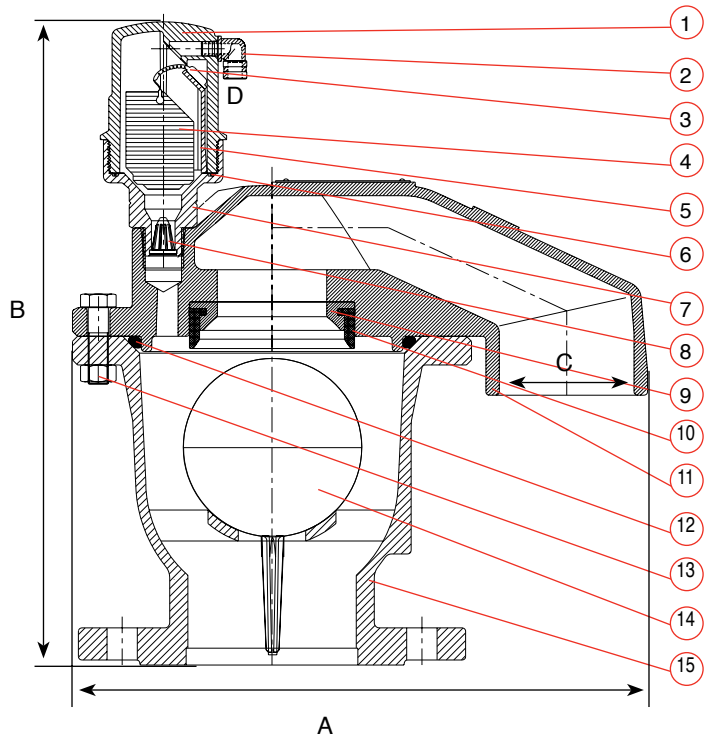

PARTS LIST AND SPECIFICATION 2", 3"

No	Part	Material
1.	Shell	Ductile Iron
2.	Body	Reinforced Nylon
3.	Air Release Outlet	Brass
4.	Rolling Seal	EPDM
5.	Float	Foamed Polypropylene
6.	Clamping Stem	Reinforced Nylon
7.	O-Ring	BUNA-N
8.	Base	Brass
9.	Strainer	Nylon
10.	Cover	Ductile Iron
11.	Orifice Seat	Bronze
12.	Orifice Seal	EPDM
13.	O-Ring	BUNA-N
14.	Bolt, Nut & Washer	Steel, Zinc Cobalt coated
15.	Body	Ductile Iron
16.	Float	Polycarbonate / Stainless steel 316

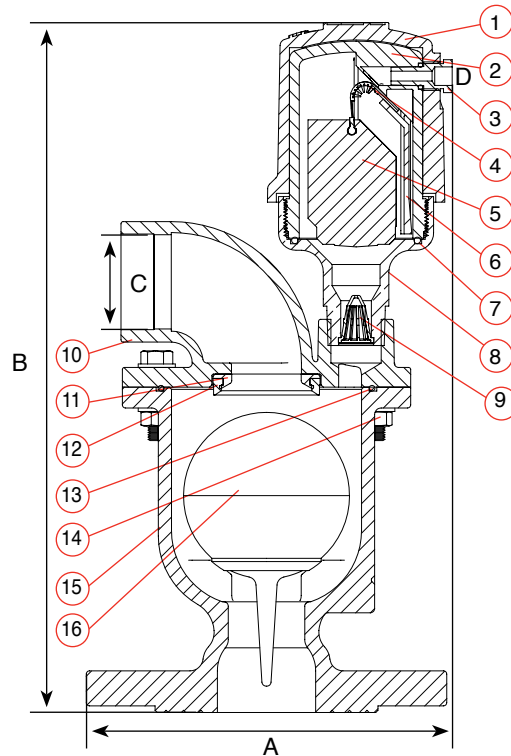

PARTS LIST AND SPECIFICATION 4", 6", 8"

No. Part	Material
1. Shell	Ductile Iron
2. Body	Reinforced Nylon
3. Air Release Outlet	Brass
4. Rolling Seal	EPDM
5. Float	Foamed Polypropylene
6. Clamping Stem	Reinforced Nylon
7. O-Ring	BUNA-N
8. Base	Brass
9. Strainer	Nylon
10. Orifice Seat	Bronze
11. Orifice Seal	EPDM
12. Cover	Ductile Iron
13. O-Ring	BUNA-N
14. Bolt, Nut & Washer	Steel Zinc Cobalt Plated
15. Float	Polycarbonate / Stainless Steel 304L
16. Body	Ductile Iron

