

D-023 PN 16 / 25



Combination Air Valve for Wastewater **PATENTED**

Description

The D-023 Combination Air Valve combines an air & vacuum component and an air release component in a single body. The valve is specifically designed to operate with liquids carrying solid particles such as wastewater and effluents. The combination air valve discharges air (gas) during the filling or charging of the system, admits air into the system during drainage and at water column separation and releases accumulated air (gas) from the system while it is operating under pressure. The valve's unique design enables the separation of the liquid from the sealing mechanism and assures optimum working conditions.

Applications

- Pump stations for sewage, waste water & water treatment plants.
- Wastewater and effluent water transmission lines.

Operation

The air & vacuum component discharges air at high flow rates during the filling of the system and admits air into the system at high flow rates during drainage and at water column separation. High velocity air will not blow the float shut. Water will lift the float which activates the sealing of the valve.

At any time during system operation, should internal pressure of the system fall below atmospheric pressure, air will enter the system. The smooth discharge of air reduces pressure surges and other destructive phenomena.

The intake of air in response to negative pressure protects the system from destructive vacuum conditions and prevents damage caused by water column separation. Air entry is essential to efficiently drain the system.

The air release component releases entrapped air in pressurized systems.

Without air valves, pockets of accumulated air may cause the following hydraulic disturbances:

- Restriction of effective flow due to a reduction of the flow area. In extreme cases this will cause complete flow stoppage.
- Obstruction of efficient hydraulic transmission due to air flow disturbances.
- Acceleration of cavitation damages.
- Increase in pressure transients and surges.
- Internal corrosion of pipes, fittings and accessories.
- Dangerous high-energy bursts of compressed air.
- Inaccuracies in flow metering.

As the system fills and is pressurized, the combination wastewater air valve functions in the following stages:

1. Air (gas) is discharged by the valve.
2. When the liquid level reaches the valve's lower portion, the float is lifted, pushing the sealing mechanism to its sealing position.
3. The entrapped air is confined in a pocket between the liquid and the sealing mechanism. The air pressure is equal to the system pressure.
4. Increases in system pressure compress the trapped air in the upper section of the conical chamber. The conical shape assures the height of the air gap. This enables separation of the liquid from the sealing mechanism.
5. Entrapped air (gas), accumulating at peaks and along the system, rises to the top of the valve and displaces the liquid in the valve's body.
6. When the liquid level lowers to a point where the float is no longer buoyant, the float drops, unsealing the air release seal. The air release orifice opens and allows part of the air that accumulated in the upper portion of the valve to be released to the atmosphere.
7. Liquid enters the valve. The float rises, pushing the air release seal to its sealing position. The remaining air gap prevents the wastewater from fouling the mechanism.

When internal pressure falls below atmospheric pressure (negative pressure):

1. The float will drop down, immediately opening the air & vacuum and air release orifices.
2. Air will enter into the system.

Main Features

- Working pressure range:
 - 0.2 - 16 bar
 - 0.2-25 bar (for 3"-4" Cast models).
- Testing Pressure: 1.5 times the working pressure of the air valve.
- Maximum working temperature: 60° C.
- Maximum intermittent temperature: 90° C.
- The unique design of the valve prevents contact between the wastewater and the sealing mechanism by creating an air gap at the top of the valve. These features are achieved by:
 1. **The conical body shape and the external lever:** designed to maintain the maximum distance between the liquid and the sealing mechanism and still obtain minimum body length.
 2. **Spring-guided linkage between the float/rod assembly and the sealing mechanism:** allows free movement of the float and rod.

Vibrations and movement of the float due to turbulence will not unseat the sealing mechanism.

3. **Funnel-shaped lower body:** designed to ensure that residue wastewater matter will fall back into the system and be carried away by the main pipe.

4. **Spray Guard®:** minimizes liquid spray discharge from the air valve outlet, mainly during rapid pipeline filling conditions.

- All inner metal parts made of stainless steel.
- Unique design of external lever prevents contact between the wastewater and the sealing mechanism, prevents clogging by floating solids and ensures drip-tight sealing.
- The D-023's orifice plug-disc linkage assembly is external, keeping the levers and pins outside the air valve body and its corrosive atmosphere.
- Discharge outlet enables for the connection of a vent pipe.
- The ball valve can be opened to release trapped pressure and drain the valve body prior to maintenance and for back-flushing during maintenance.

Valve Selection

- Size range availability: 3" - 8".
- Valves manufactured with flange ends to meet any requested standard.

- The 3" valve is also available with a threaded BSP or NPT connection.

- Standard welded/cast steel body, also available in stainless steel.
- Valve body coating: fusion bonded epoxy coating in compliance with standard DIN 30677-2.

- Additional coatings available upon request.

- Optional Accessories

- With a One-way, Out-only attachment, allows for air discharge only, prevents air intake.
- With a Vacuum Breaker, In-only attachment, allows for air intake only, prevents air discharge.
- With a Non-Slam discharge-throttling attachment, allows for free air intake, throttles air discharge - Model D-023 NS.

Note

- The D-023 air valve is intended for use with raw wastewater. For use with aggressive liquids, please consult with our application engineers or with the marketing dept.

- For best suitability, it is recommended to send the fluid chemical properties along with the valve request.

- Upon ordering, please specify: model, size, working pressure, thread and flange standard and type of liquid.

AIR & VACUUM FLOW RATE

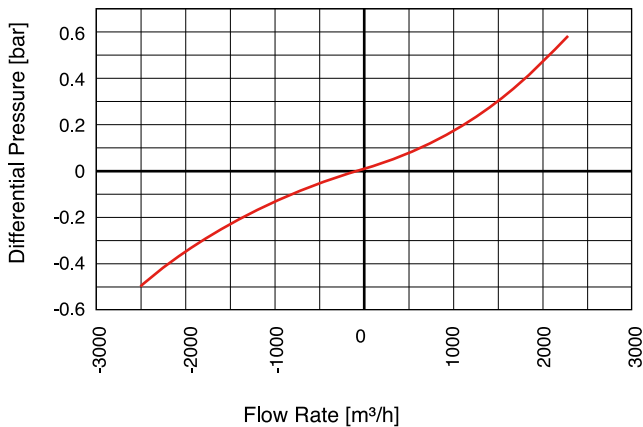

AUTOMATIC AIR RELEASE FLOW RATE

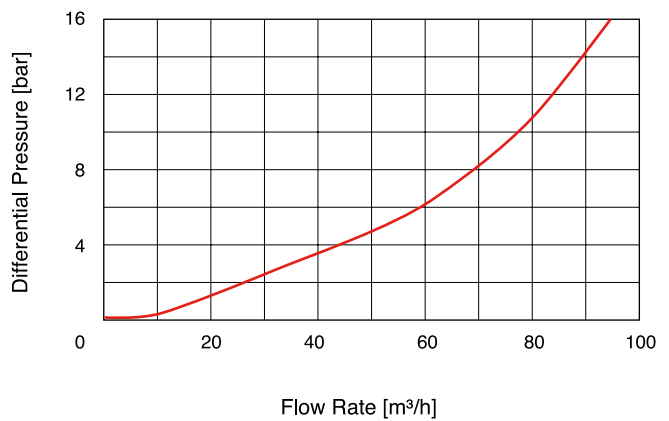

DIMENSIONS AND WEIGHTS

Nominal Size	Dimensions mm		Connection C	Weight Kg.	Orifice Area mm²	
	A	B			Auto.	A / V
3" (80 mm)	554	580	3" BSP / NPSM Female	25	15.7	5024
4" (100 mm)	554	580	3" BSP / NPSM Female	26.5	15.7	5024
6" (150 mm)	554	580	3" BSP / NPSM Female	28	15.7	5024
8" (200 mm)	554	580	3" BSP / NPSM Female	30	15.7	5024

PARTS LIST AND SPECIFICATION

No.	Parts	Material
1.	Disk Arm Assembly	Cast ST ST + EPDM
2.	Cover	Ductile Iron / Cast ST ST
3.	Orifice Seat	ST ST 316
4.	Plug	Polypropylene
5.	Air & Vacuum Disc	Reinforced Nylon/ Cast ST ST
6.	Washer	ST ST 304
7.	Rivet	ST ST 304
8.	Air Release Seal	EPDM
9.	Air Release Disc	Reinforced Nylon
10.	Bolt	ST ST 304
11.	O-RING	BUNA-N
12.	Air & Vacuum Seal	EPDM
13.	Air & Vacuum Seal Lock	Reinforced Nylon
14.	Domed Nut & Washer	ST ST 304
15.	Spray Guard®	Polypropylene
16.	Stopper	Polypropylene
17.	Spring	ST ST 316
18.	Washer	ST ST 304
19.	Body	3"-4" Carbon Steel / ST ST 316 / Cast Steel / Cast ST ST 6"-8" Carbon Steel / ST ST 316
20.	Float Assy.	Polypropylene + ST ST 316
21.	Ball Valve	Brass, Chrome Coated / ST ST 316
22.	Bolt	ST ST 316
23.	Washer	ST ST 316
24.	Bushing	Acetal
25.	Bolt, Nut & Washer	ST ST 316
26.	Domed Nut	ST ST 316

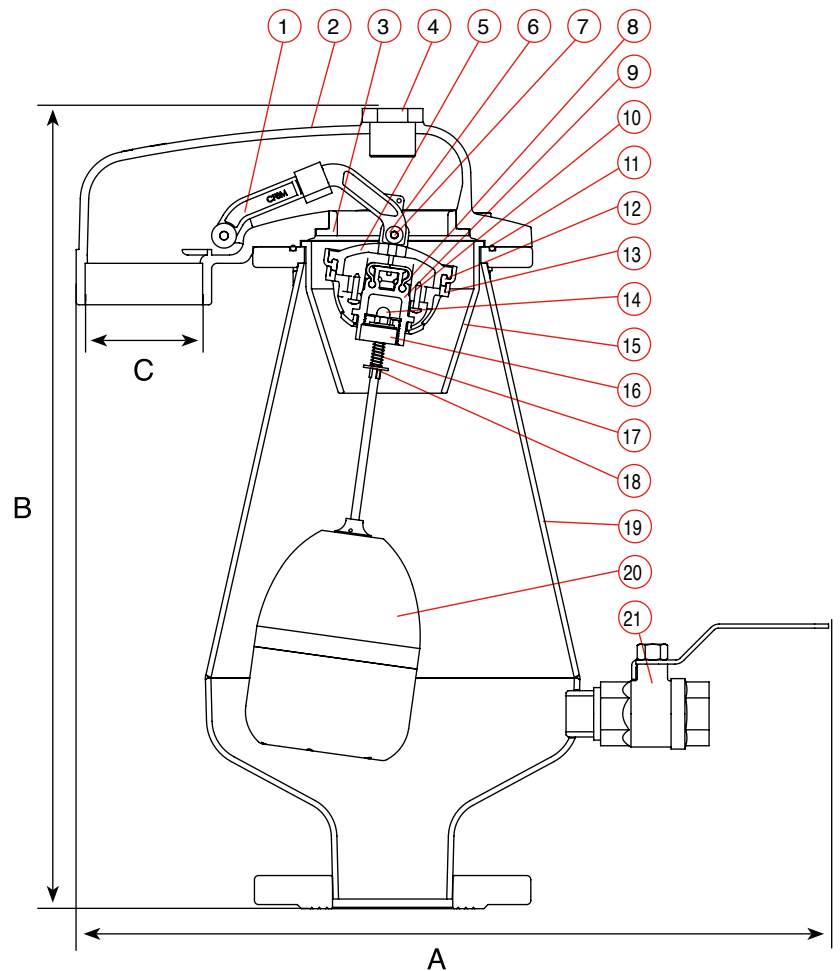
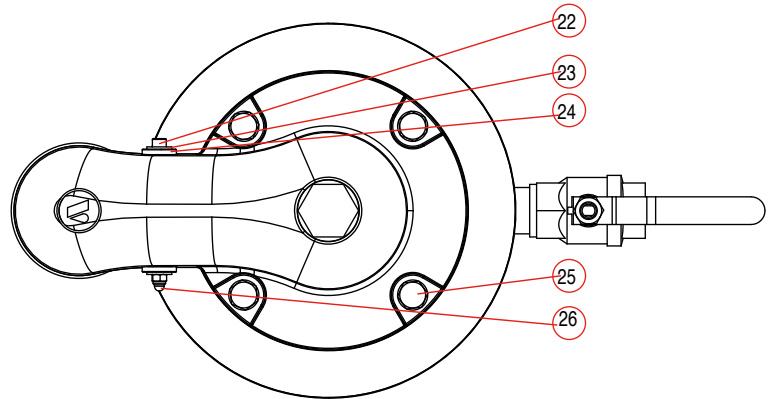

Two-directional discharge outlet cover

The D-023 combination air valve for wastewater is available with an optional stainless steel two-directional discharge outlet cover.

One outlet is always open for air discharge while the other is closed with a plug. Both outlets have a 3" female thread.

With this option, air can be discharged either in a horizontal or vertical direction, depending on the installation. This option allows for easy vertical air discharge from valves installed in manholes.

This cover is standard on all D-023 SB underground air valves and is optional for all D-023 air valves, both stainless steel and epoxy coated.

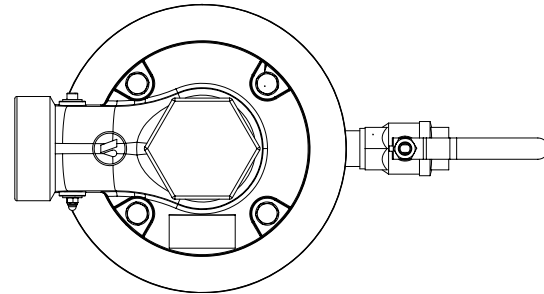
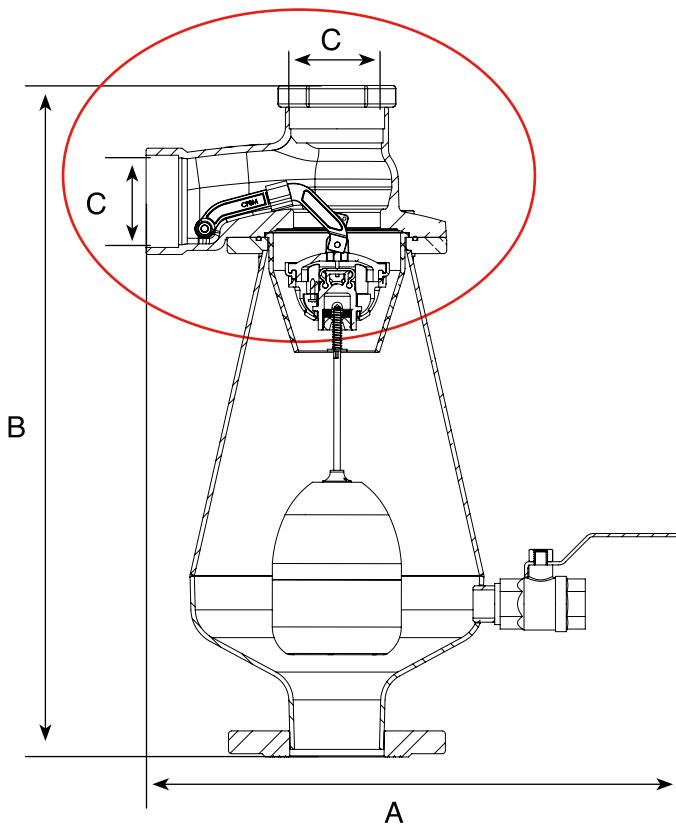

DIMENSIONS AND WEIGHTS

Nominal Size	Dimensions mm		Connection C	Weight Kg.	Orifice Area mm ²	
	A	B			Auto.	A / V
3" (80 mm)	500	620	3" BSP / NPSM Female	25	15.7	5024
4" (100 mm)	500	620	3" BSP / NPSM Female	26	15.7	5024
6" (150 mm)	500	620	3" BSP / NPSM Female	27.5	15.7	5024
8" (200 mm)	500	620	3" BSP / NPSM Female	30.5	15.7	5024

Combination Air Valve for Wastewater - Non Slam

The D-023 Combination Wastewater Non Slam accessory will dampen surge and prevent slam. The non slam accessory provides efficient surge suppression.

At sudden drainage and/or water column separation (sudden pump trips or valve closure, for instance), the air & vacuum orifice admits air at high flow rates, thus preventing vacuum. As the water column and/or pressure wave returns, the large volumes of air are exhausted slowly through the smaller orifice of the non-slam accessory. This slowly exhausting air pocket dampens the slam of the returning water column, thus suppressing the pressure surge. As the water flow arrives at a much slower rate, dampened by the slower air discharge, it buoys up the main float, gently closing the air & vacuum component of the air valve.

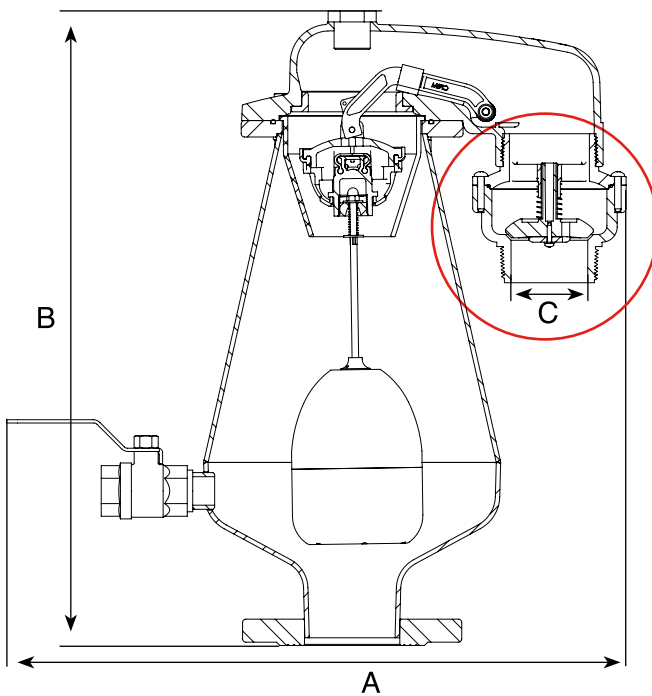

WITH ADJUSTABLE NS C.V.

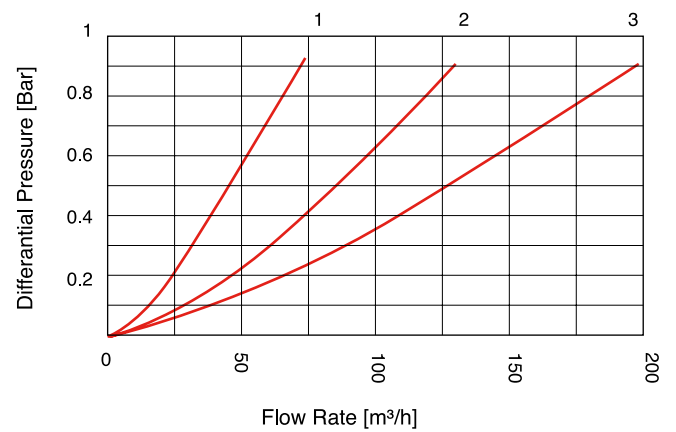
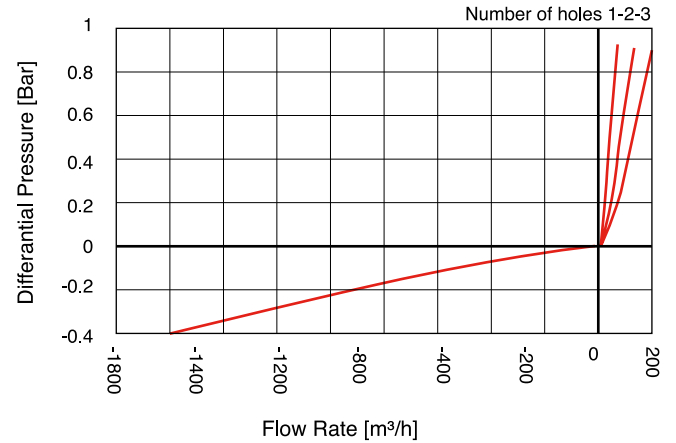

DIMENSIONS AND WEIGHTS

Nominal Size	Dimensions mm		Connection C	Weight Kg.	Orifice Area mm ²	
	A	B			Auto.	A / V
3" (80 mm)	610	620	3" BSP / NPSM Male	25.76	15.7	5024
4" (100 mm)	610	620	3" BSP / NPSM Male	26.76	15.7	5024
6" (150 mm)	610	620	3" BSP / NPSM Male	28.26	15.7	5024
8" (200 mm)	610	620	3" BSP / NPSM Male	31.26	15.7	5024

D-023 NS Non-Slam Add-on Component Data Table for Variable Orifices

Model	Discharge orifice mm	Total NS area mm ²	NS orifice mm	Switching point	Flow at 0.4 bar m ³ /h
1 orifice	75	50.3	8	Spring loaded normally closed	40
2 orifice	75	100.5	11.3		75
3 orifice	75	150.8	13.9		105

