



# DG-10 PN 10

# D-040 PN 16



## Combination Air Valve "Barak"

### Description

The combination air valve has the features of both an air release valve and an air & vacuum valve.

The air release component of the combination air valve was designed to automatically release small pockets of air to the atmosphere as they accumulate along a pipeline or piping system when it is full and operating under pressure.

The air & vacuum component was designed to automatically discharge or intake large volumes of air during the filling or draining of a pipeline or piping system. This valve will open to relieve negative pressures whenever water column separation occurs.

### Applications

- Pump stations: after the pump and after the check valve.
- Head system.
- At the end of lines and at the end of a sub main.
- On strainers and filters.

### Operation

The air & vacuum component, with the large orifice, discharges air at high flow rates during the filling of the system and intakes air into the system at high flow rates during its drainage and at water column separation.

High velocity air should not blow the float shut. Water will lift the float and cause sealing of the valve.

At any time during system operation, should internal pressure of the system fall below atmospheric pressure, air will re-enter the systems, reducing down-surges and cavitations.

The smooth release of air prevents pressure surges and other destructive phenomena.

The intake of air in response to negative pressure protects the system from destructive vacuum conditions and prevents damage caused by water column separation. Air re-entry is essential to efficiently drain the system.

The automatic small orifice air release component releases entrapped air in pressurized systems.

**Without air valves, pockets of accumulated air may cause the following destructive phenomena:**

- Obstruction to effective flow and hydraulic conductivity of the system along with a throttling effect similar to a partially closed valve. In extreme cases this will cause complete flow stoppage.
- Accelerate cavitation damages.
- High-pressure surges.
- Accelerate corrosion.
- Danger of a high-energy burst of compressed air.

**As the system starts to fill, the valve functions according to the following stages:**

1. Entrapped air is released by the valve
2. Liquid enters the valve, lifting the float which rolls the flexible rolling seal to its sealing position.
3. Entrapped air, which accumulates at peaks along the system (where combination air valves should be installed), rises to the top of the valve, which in turn displaces the liquid in the valve's body.
4. The float descends, rolling the flexible rolling seal away from the smaller orifice, the smaller orifice opens and the accumulated air is released.
5. Liquid penetrates into the valve and the float rises rolling the flexible rolling seal back to its sealing position.

**When internal pressure falls below atmospheric pressure (negative pressure):**

1. Both orifices will be immediately unplugged and the float drops away.
2. Air is re-entered into the system.

### Main Features

- Working pressure range: **DG-10** 0.1-10 bar. **D-040** 0.2-16 bar
- Testing pressure: **DG-10** 16 bar. **D-040** 25 bar.
- Working Temperature: 60<sup>0</sup> C.
- Maximum short-term temperature: 90<sup>0</sup> C.
- The body is made of high strength composite materials and all operating parts are made of specially selected corrosion-resistant materials.
- The larger than usual orifice enables it to release air at higher flow rates than other automatic air release valves of its kind.
- The enlarged orifice with its self-cleaning mechanism dramatically reduces obstruction due to debris.
- The valve's rolling seal mechanism design is less sensitive to different pressures than a direct float seal, thus enabling a one-size orifice for a wide pressure range (from 0.2 up to 16 bar).
- Light, simple and reliable structure.
- Due to its light weight, the valve may be installed on plastic piping systems, as well as other light weight piping.

### Valve Selection

The air valve is available:

- With 3/4", 1", 2" male BSPT/NPT connections.
- With a ball valve tap BSPT/NPT male connection upon request.
- The valve is available with a one-way check valve.

When ordering, please specify valve type according to the maximum working pressure of the line.

## AIR AND VACUUM FLOW RATE

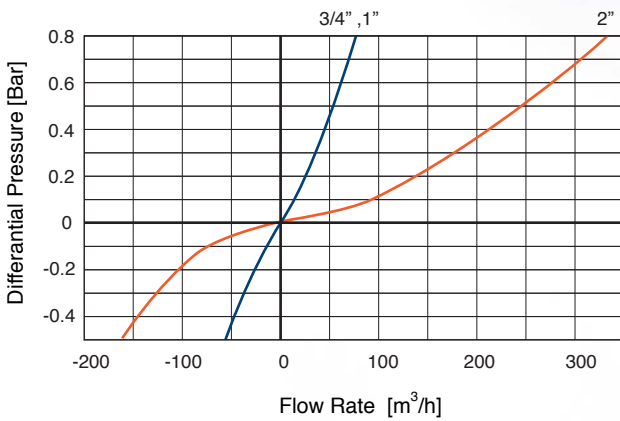

## AUTOMATIC AIR DISCHARGE

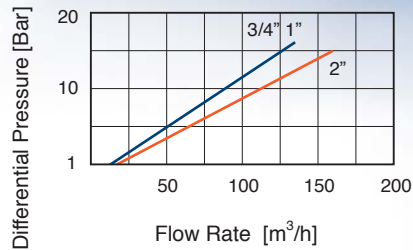

## DIMENSIONS AND WEIGHTS

Model	Dimensions mm			Weight Kg.	Orifice Area mm <sup>2</sup>	
	A	B	C		Auto.	A / V
1", 3/4"	100	143	3/8" BSP	0.33	7.8	100
2"	180	209	1 1/2" BSP	1.1	12	804

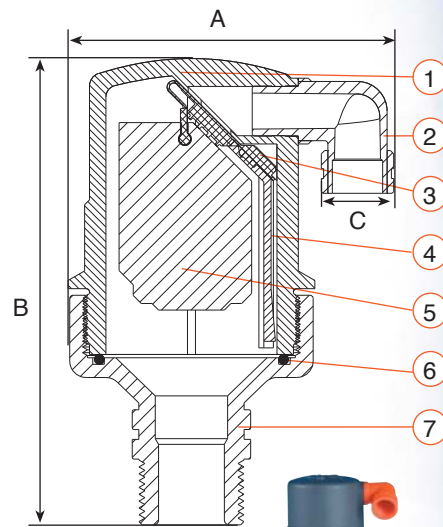

3/4" 1"

## PARTS LIST AND SPECIFICATION

No.	Part	Material
1.	Body	Reinforced Nylon
2.	Drainage Outlet	Polypropylene
3.	Seal Plug Assembly	
3a.	Screws	Stainless Steel
3b.	Plug Cover	Reinforced Nylon
3c.	Rolling Seal	E.P.D.M.
3d.	Plug	Reinforced Nylon
4.	Clamping Stem	Reinforced Nylon
5.	Float	Foamed Polypropylene
6.	O-Ring	BUNA-N
7.	Base	Reinforced Nylon
<b>Optional</b>		
	Ball valve	Brass ASTM B124

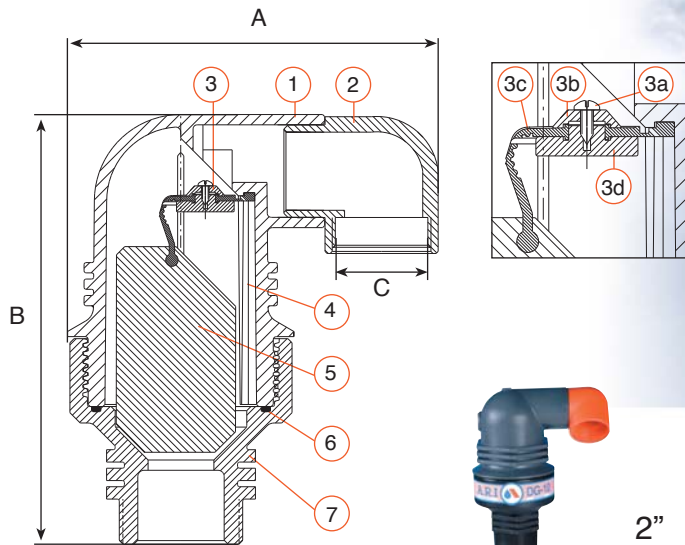

2"